

CHALWYN

DIESEL PROTECTION SYSTEMS

D-Series Automatic Engine Overspeed Shut Down Valves (Mini Range)

SELECTION, APPLICATION AND MAINTENANCE

Valve Numbers
D29, D30, D34BF, D35BF, D39BF,
D30B-AM, D34BF-AM, D35BF-AM, D39BF-AM

DESCRIPTION

A range of small spring loaded poppet valves designed to automatically stop an engine by closing down the air intake should excessive overspeeding occur.

The closing force on the valve is provided by the intake air flow passing through. As the air flow increases, the closing force builds up. This is resisted by a spring, the pre-load of which is adjustable such that at a given air flow the resulting force overcomes the spring resistance and causes the valve to close. Once closed the valve will not reset to the open condition until the engine stops.

This type of valve may be fitted to either naturally aspirated or turbocharged engines. It should be noted however that for a given valve setting the repeatability of the actual automatic shut down speed has a greater scatter in the case of a turbocharged engine. However, unless for special reasons a precisely repeatable shut down speed is required, adequate protection from excessive overspeed and potential resulting damage is still achieved.

Types D34BF, D34BFS, D35BF, D35BFS, D39BF and D39BFS all include an integral engine air cleaner. Types D29 and D30 are not available with an integral air cleaner.

A manual shut down option is available for all types.

Basic Dimensions: D29 and D30 Ranges

Valve Type	Auto Overspeed Only	Auto Overspeed and Manual Shut Down	Outside Diameter 'A' (Size range in mm)		'B' (mm)	'C' (mm)	Ø 'D' (mm)	Approximate Weight (Kg)
			Minimum	Maximum				
D29	✓		25mm (1")	34mm (1 1/32")	52	15	63	0.3
D29-AM		✓						
D30	✓		35mm (1 3/8")	45mm (1 3/4")	52	15	63	0.3
D30-AM		✓						

VALVE TYPE D30-AM

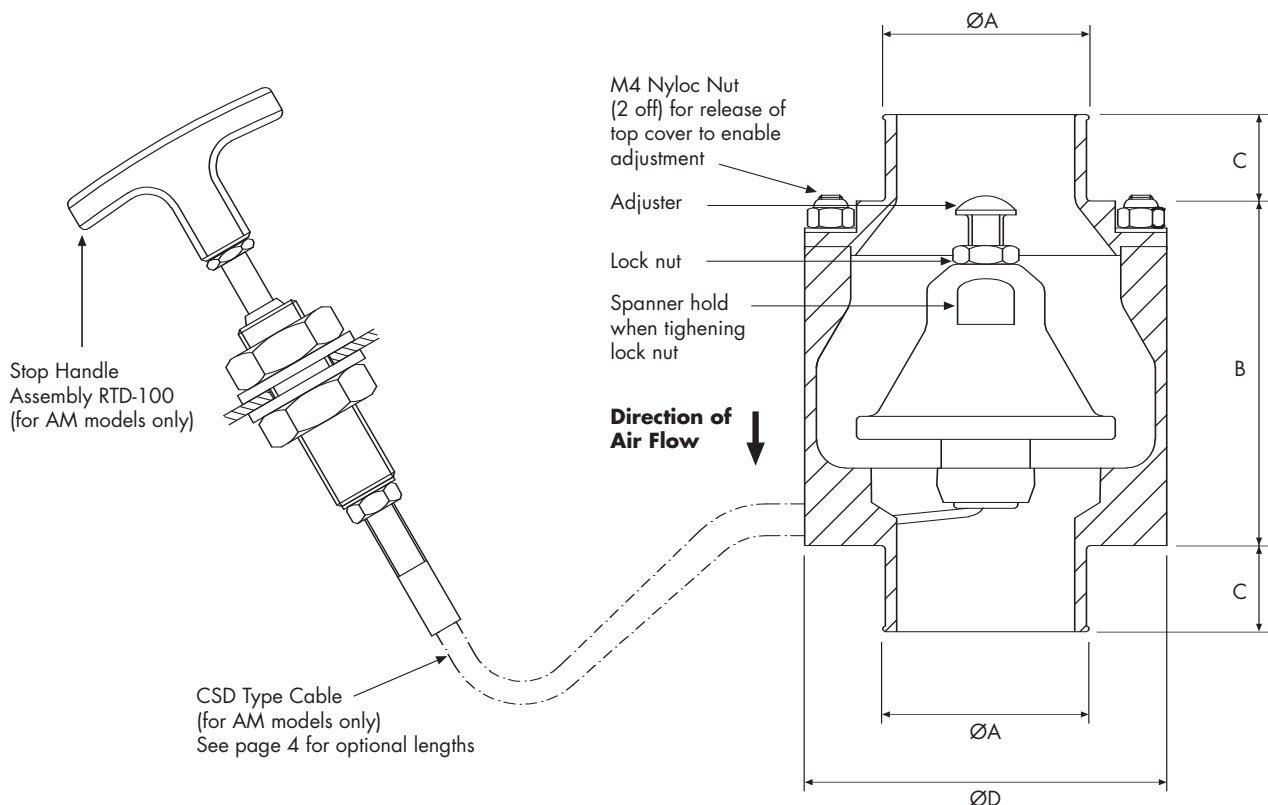

Basic Dimensions: D34BF, D35BF and D39BF Valves.

Valve	Auto Overspeed Only	Auto Overspeed and Manual Shut Down	Ø 'A' (mm)	'B' (mm)	Ø 'C' (mm)	Weight (Kg)
D34BF-35	✓		35	164	158	1.2
D34BF-AM-35		✓	35	186	158	1.3
D34BF-38	✓		38	164	158	1.2
D34BF-AM-38		✓	38	186	158	1.3
D35BF-35	✓		35	164	158	1.2
D35BF-AM-35		✓	35	186	158	1.3
D35BF-38	✓		38	164	158	1.2
D35BF-AM-38		✓	38	186	158	1.3
D39BF-40	✓		40	164	158	1.2
D39BF-AM-40		✓	40	186	158	1.3
D39BF-42	✓		42	164	158	1.2
D39BF-AM-42		✓	42	186	158	1.3
D39BF-44	✓		44	164	158	1.2
D39BF-AM-44		✓	44	186	158	1.3

The same basic dimensions apply to the equivalent D34BFS, D35BFS and D39BFS types

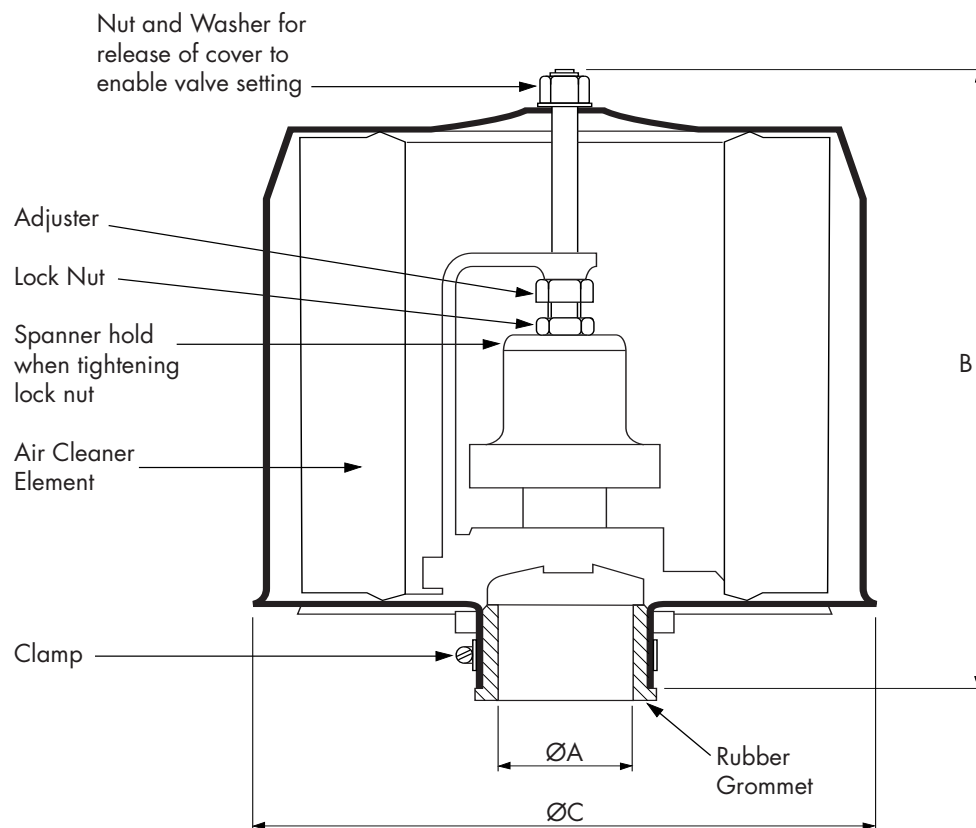
VALVE TYPE D35BF-38

SELECTION

1. From the table below, select the valve type to suit the power output of the engine.

Valve type	Engine Power at Rated Speed	
D29	1.5 to 8kW	(2 to 11hp)
D30	5 to 18kW	(4 to 24hp)
D34BF	1 to 2kW	(1 to 3hp)
D35BF	3 to 11kW	(4 to 15hp)
D39BF		
D35BFS	12 to 20kW	(16 to 27hp)
D39BFS		

Note: Above recommended power ranges are applicable to all variants of each valve type.

2. For the valve type identified in 1, select the required diameter $\varnothing A$ - see pages 2 or 3. Note the end tubes of the D29 and D30 valves are designed to fit into the bore of the engine air intake hose. The rubber grommets of the D34, D35 and D39 types are designed to push over the outside diameter of a metal air intake pipes.

3. When the manual shut down option is specified, select the length of shut down cable required from the table below. Note, other lengths may be available on request.

Cables for D29 and D30 Valves	Cables for D34BF, 35BF & D39BF Range Valves	Length (metres)
CSD-100	CLD-100	1.0
CSD-150	CLD-150	1.5
CSD-200	CLD-200	2.0
CSD-300	CLD-300	3.0

Note: For larger sizes of 'D' valves see Chalwyn data sheets CE204, CE205 and CE231.

FITTING

1. Valves with the manual shut down option are supplied complete with the manual stop cable and 'T' handle fitted and adjusted. Do not separate cable from handle or valve. (See paragraph 5)
2. It is recommended that D29 and D34BF valves are fitted with the air flow direction towards the engine between horizontal and vertically downwards. All other Chalwyn Mini Valves can be fitted at any attitude subject to correct functioning as established during adjustment - see page 6. For D29 and D30 range valves also ensure that:-
 - a) *The engine intake air flow direction is as marked on the valve.*
 - b) *If an intake flametrap is fitted, the valve is installed between the air cleaner and flametrap.*
 - c) *The hose into which the valve is fitted provides adequate support and prevents excessive vibration. If necessary support brackets should be considered taking into account relative movement between the valve and engine.*
3. Particular care must be taken to ensure the integrity of the pipework between the Chalwyn valve and engine intake manifold. Ideally metal pipework should be used. Where unavoidable, gaps in the metal pipework should be as short as possible, (taking into account any relative movement) and connected by re-inforced rubber hose. The possibility of hose collapse on closure of the valve must be avoided.
4. Any engine crankcase breather connections into intake system between the Chalwyn valve and engine, or any internal crankcase breather arrangement venting directly into the engine intake ports, must be sealed and replaced by a external breather system venting either to atmosphere or to the intake system upstream of the shut down valve. External breather system kits for various engine types are available from Chalwyn.
5. For valves fitted with the manual shut down option, fit the 'T' handle assembly RTD-100 through a suitable $\text{Ø}20\text{mm}$ ($3/4"$) hole in a bulkhead or mounting bracket as follows. Release the handle locknut. Remove the handle, handle locknut and upper locknut and washer. Thread handle body through the bulkhead/bracket. Refit upper locknut and washer. Adjust lower and upper locknuts to position handle and tighten. Refit handle locknut and handle. Tighten locknut.

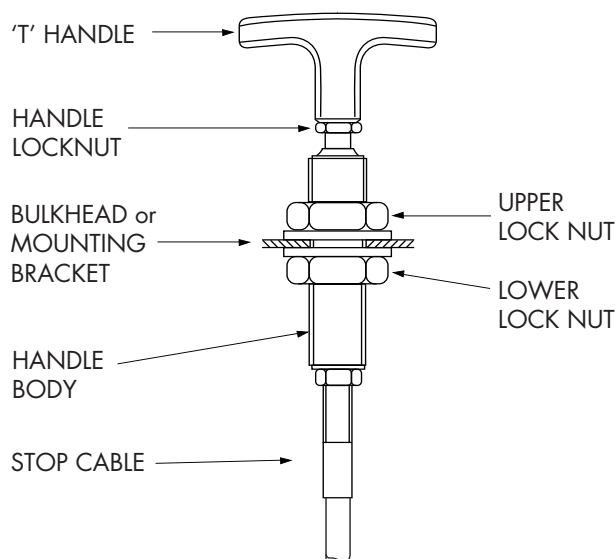

ADJUSTMENT

Once the Chalwyn valve is installed, adjustment of the overspeed trip setting is carried out using the adjuster and locknut (refer to diagrams). Basically rotating the adjuster clockwise will increase the engine speed at which automatic shut down occurs.

As supplied, the valve will be adjusted such that shut down will generally occur well below the engine high idle speed. To increase the speed at which automatic shut down occurs, proceed as follows:

1. If the manual shut down option is fitted check that the shut down cable is set to the run position ('T' handle pushed in) throughout the adjustment procedure.
2. Start engine. Slowly accelerate. Note speed at which shut down occurs.
3. In the case of D29 and D30 range valves remove the inlet hose and top cover. For D34/D35/D39 valves remove the air cleaner cover and filter element.
4. Release adjuster lock nut. Turn adjuster one turn clockwise. Tighten locknut.
5. Refit all parts (including the air inlet hose in the case of D29 and D30 range valves).
6. Start engine - Slowly accelerate. Note speed at which shut down occurs.
7. Repeat steps '3' to '6' until the first setting at which the engine does not shut down at high idle speed (i.e. maximum throttle, no load). Then either:
 - a) Use the results of shut down speed versus adjuster setting as a calibration check to make a final adjustment to give the required setting (typically 10% to 15% over high idle).
 - or**
 - b) If a very precise setting is not required, turn the adjuster a further one turn clockwise to take the shut down above high idle speed by a suitable margin. When using this setting procedure it may be found that the engine occasionally shuts down during the normal operation. If so, turn the adjuster clockwise by a further one half turn.
8. Finally ensure the adjuster locknut is fully tightened. (Use a thread lock adhesive on the locknut threads).
9. For valves with manual shut down re-start engine and check the manual shut down functions correctly.

Notes:

Turbocharged Engines.

When setting a valve fitted to a turbocharged engine using the preceding method, it may be found that at high engine power outputs, the engine will shut down at a lower speed than required. If this occurs, further small adjustments in steps of one half turn clockwise should be made until the problem is eliminated.

Insufficient Adjustment.

Should there be insufficient adjustment to set the shut down speed at the required level contact your Chalwyn Distributor to check for correct valve spring selection.

Jammed Valve.

If in the course of adjusting the valve it jams on its seat, release by turning **CLOCKWISE** viewed from adjuster end

MAINTENANCE

Shut Down Valve and Mechanism

The recommended routine maintenance period is three months. This period is dependent on the operating conditions of the engine and, by experience, may need to be varied.

Routine Maintenance

1. Disconnect intake pipework and release the valve from any support brackets etc. to allow it to be removed.
2. Inspect the valve internally for cleanliness. If necessary clean in paraffin or white spirit taking normal precautions. Dry the valve thoroughly.
3. Check there is no excessive wear and that the valve moves smoothly over its complete operating stroke. **DO NOT LUBRICATE.**
4. Refit valve. Check valve setting based on the "Adjustment" instructions given herein.

Note:

When excessive wear is apparent, or the valve damaged, it should be returned to Chalwyn Limited for appraisal and reconditioning. (All such work is dealt with on an urgent basis.)

Air Cleaner Element (when fitted)

Replace air cleaner element at the periods recommended by the engine manufacturer. (Spare elements are available from Chalwyn.)

CHALWYN LIMITED

Chalwyn Industrial Estate, Parkstone, Poole, Dorset BH12 4PF ENGLAND

Tel: +44(0)1202 715200 Fax: +44(0)1202 715600

www.chalwyn.co.uk

