

# **CHALWYN**

DIESEL PROTECTION SYSTEMS

## **Self Exciting Flame proof Alternator**

### **INSTALLATION, OPERATION & MAINTENANCE**

**Alternator Types**

**ASX-310**

## DESCRIPTION

Twelve pole rotating field coil type self exciting alternators. To provide a speed signal and sufficient power output to charge a typical small to medium sized diesel engine start battery. Designed as Category 2G/D equipment and marked :

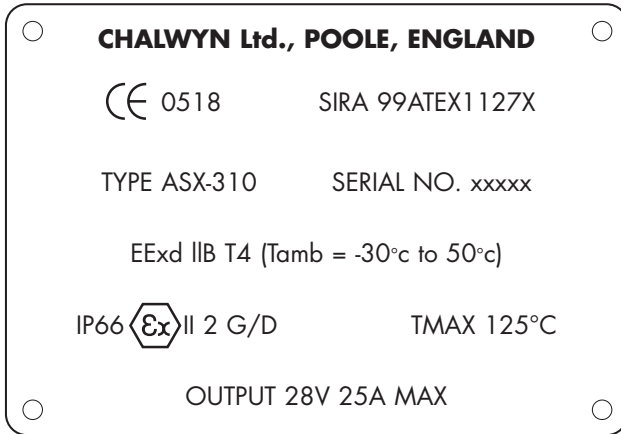

ASX-310 alternators also meet the Electromagnetic Compatibility (EMC) requirements of MIL STD 461E Clauses RE102 and RS103.

The outer enclosure of these alternators is manufactured from LM 25 die castings. Fan, fan discs, cowls and pulleys are manufactured from carbon steel. Overall dimensions are as given below.

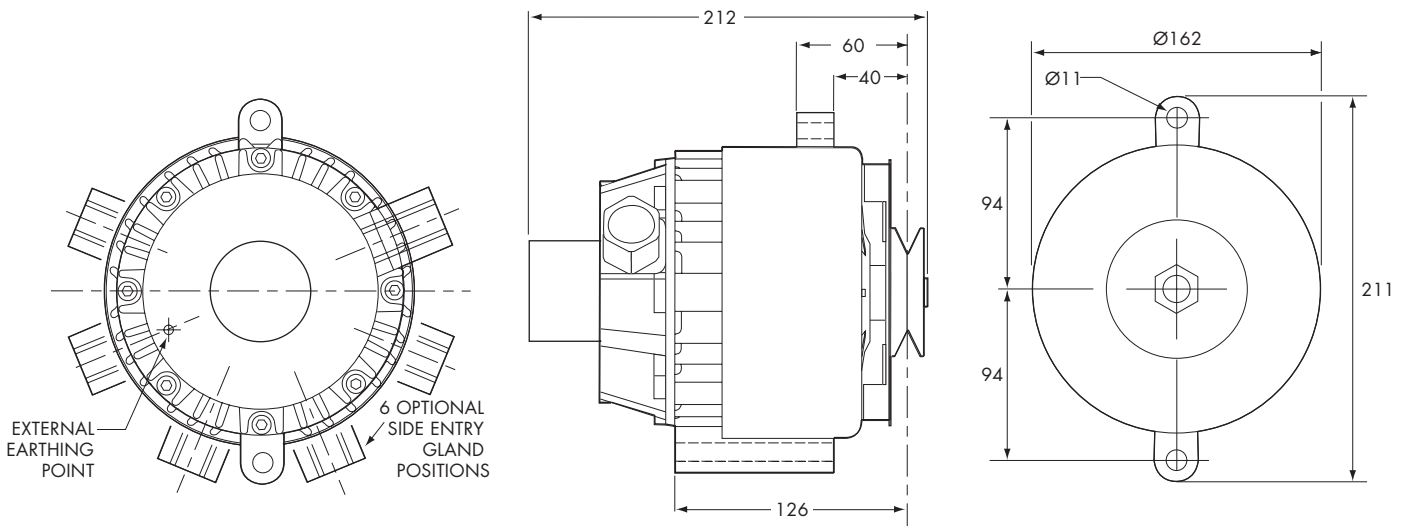

### Note:

To maintain full compliance with hazardous area and EMC requirements ensure:-

- a. The external earthing point of the alternator and any armoured/screened cable are properly bonded to the engine/engine frame.
- b. Any connected electrical equipment is engineered to the requisite standard.

## APPLICATION

The ASX-310 is designed for application as a belt driven diesel engine mounted alternator for use in hazardous areas classified as zone 1, group IIB, T4. It is suitable for a local ambient temperature range between -30°C and +50°C. This equipment must not be used for other applications/ambient conditions without the prior approval of Chalwyn Limited.

The continuous alternator output must not exceed 25 amperes.

### **Important Note:**

If a significant proportion of the alternator output is used to light incandescent lamps, due allowance must be made for the low cold electrical resistance and hence current surge when the lamps are first lit. When the ASX-310 is used to power the Chalwyn Series 110 engine shut down control system a special circuit external to the ASX-310 is incorporated to limit any such high transient current and hence any lamps powered via the Series 110 may take a few seconds to reach full brightness. If no current limiting circuit is incorporated and the engine started with a significant incandescent lamp load in circuit or, if a significant incandescent lamp load is switched on whilst the engine (alternator) is running at low speed, the ASX-310 may fail to excite or cease to excite until the engine is run up to moderate/high speed.

## INSTALLATION

1. Remove any existing non flame proof alternator from the diesel engine.
2. Check the alternator drive pulley ratio. In the case of fixed speed applications the pulley drive should be arranged to give a continuous alternator speed of between 5,000 rpm and 7,000 rpm. In the case of variable speed applications the pulley ratio should be selected to give an alternator speed of 2000 to 2,500 rpm at the engine low idle. This typically equates to a normal operating alternator speed range of about 3,500 rpm to 8,000 rpm.

### NOTE:

a) The rear cover of the alternator may be rotated to give alternative cable entry positions.

b) The standard cable entry gland supplied with the alternator is suitable for sealing on the outer sheath of unarmoured cable or on the inner sheath of armoured cable within the size range of 8.5 to 16mm diameter.

c) After installing the cable, a cable clamping device should be applied as near as possible to the cable gland.

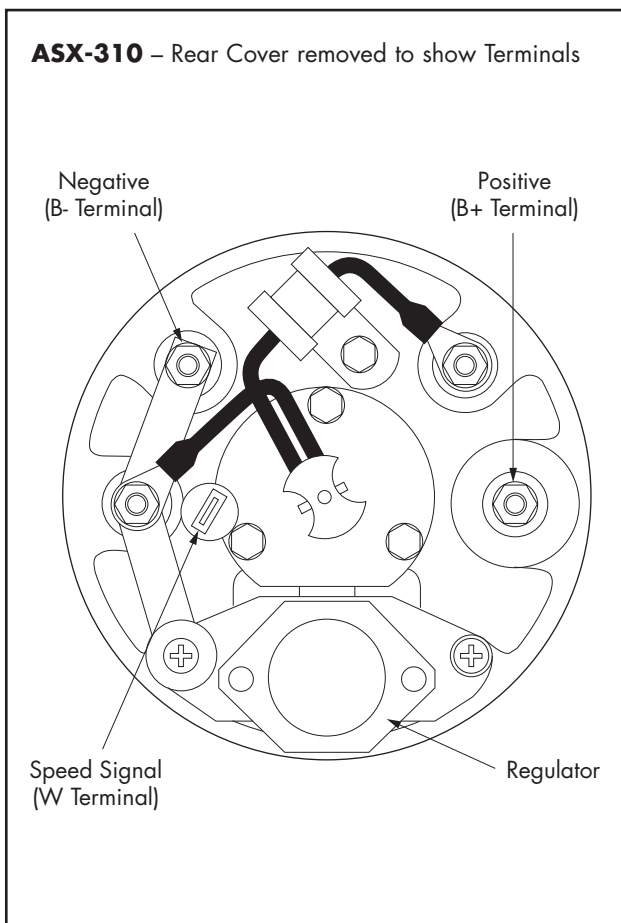

3. Prepare to fit the Chalwyn ASX-310 alternator in place of the standard alternator by modifying the support bracket and belt tensioning link as necessary. Check that adequate belt adjustment is available. Ensure that with the selected cable entry position, the alternator cable can be routed away from the alternator in such a way as to avoid potential mechanical or heat damage.

4. Remove rear cover of alternator. Prepare correctly rated cable for fitting to the terminals as shown below. Note, the main positive and negative terminals are designed for M5 ring connections. When slackening or tightening the terminal nuts, particular care should be taken not to slacken the M5 nuts at the base of the terminal posts. The speed signal connection should be made using a right angle spade connector to avoid bending the cable ( eg. RS part 161-2008). Use ties to restrain the cables to prevent mechanical damage

5. Refit the rear cover after ensuring the 'O' ring seal is undamaged and is properly seated in the seal groove. Torque the rear cover fasteners to 15Nm.

6. Fit alternator to engine. Fit external earth wire from M4 tapped hole in the Alternator rear cover to a clean position on the engine. Use a 4mm<sup>2</sup> section cable, ring terminals and shake proof washers. NOTE: Check that the engine is also electrically bonded to its base frame or equivalent.

7. Fit an antistatic (conductive) drive belt and check it is correctly tensioned.

### Special Notes:

a. The cable entry point exceeds 70°C under rated conditions, therefore, in accordance with EN 50014:1997 clause 16.8, suitably rated cable shall be selected for installation.

b. The output voltage from the alternator is controlled by an internal regulator. It is recommended however that "over voltage" protection is fitted to any circuit supplied by the alternator in which one or more components could become a potential source of ignition should "over voltage" occur.

## OPERATION

Reduce the electrical load to the minimum possible whilst starting the engine. In particular any incandescent lamps to be powered by the ASX-310 should be switched off prior to starting engine (see also "APPLICATION"). Once the engine fires and runs it may be necessary to accelerate to a moderate speed to start the alternator excitation. Once an output is established and the electrical load fully switched on the engine r.p.m. may then be reduced.

## MAINTENANCE

Routine maintenance is to be undertaken as follows :

### MONTHLY

- Check drive belt is in serviceable condition and is correctly tensioned.
- Check alternator mounting fasteners are tight.
- Check alternator cable is properly supported and free from damage.

---

### THREE MONTHLY

- Check end float at alternator cooling fan. This must not exceed 0.2mm when alternator is cold.
- Check fan to cowl clearance. At worst point this must be greater than 1.0mm.

---

### YEARLY

(or each 2,000 hours -  
whichever occurs sooner)

- Remove alternator rear cover. Loosen the two fasteners locating the regulator carefully noting the position of the insulating and steel washers (see diagram under INSTALLATION). Replace regulator and brush assembly with a new assembly ensuring the various washers are replaced correctly and the fasteners are re-tightened.
- Clear any dust from the rear cover area. Check cable condition is acceptable for further service. Check and tighten as necessary all terminals. Check rear cover 'O' ring seal is suitable for further service and is properly located in the seal groove. Refit rear cover torqueing fasteners to 15Nm. Tighten cable gland.
- Check air passages under fan cowl are clear of any significant build up of foreign matter.

---

#### Maintenance Note:

The M6 socket head cap screws utilised for fastening the end covers must only be replaced by cap screws with a yield strength better or equal to 830 N/mm<sup>2</sup> in accordance with EN 50018:1994, clause 11.3.

---

**CHALWYN LIMITED**

Chalwyn Industrial Estate, Parkstone, Poole, Dorset BH12 4PF ENGLAND

Tel: +44(0)1202 715200 Fax: +44(0)1202 715600

[www.chalwyn.co.uk](http://www.chalwyn.co.uk)

